

Subplate, Size 10 (ISO4401)

Size unit: mm

Model G534/01 (G3/4"), Model G534/02 (M27×2)
For spool directional valve

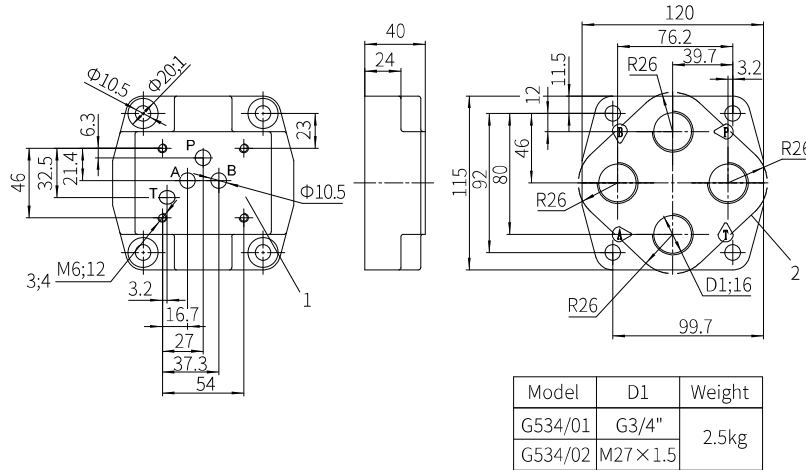

Subplate, Size 16 (ISO4401)

Size unit: mm

Model G172/01 (G3/4"), Model G172/02 (M27×2)

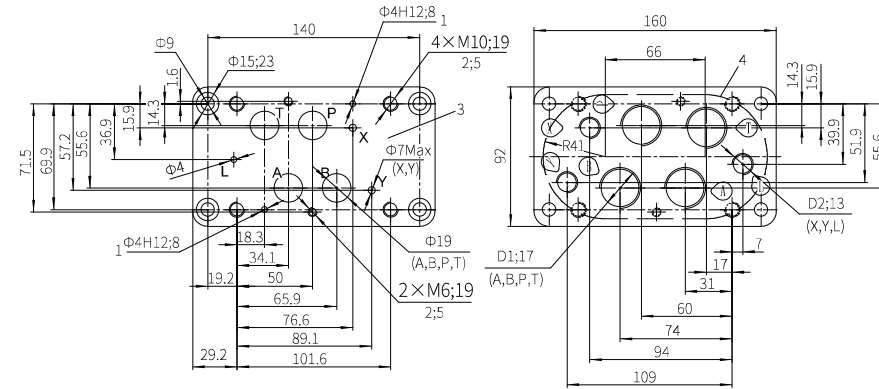

Model G535/01 (G3/4"), Model G535/02 (M27×2), Model G536/01 (G1"), Model G536/02 (M33×2)
For spool directional valve

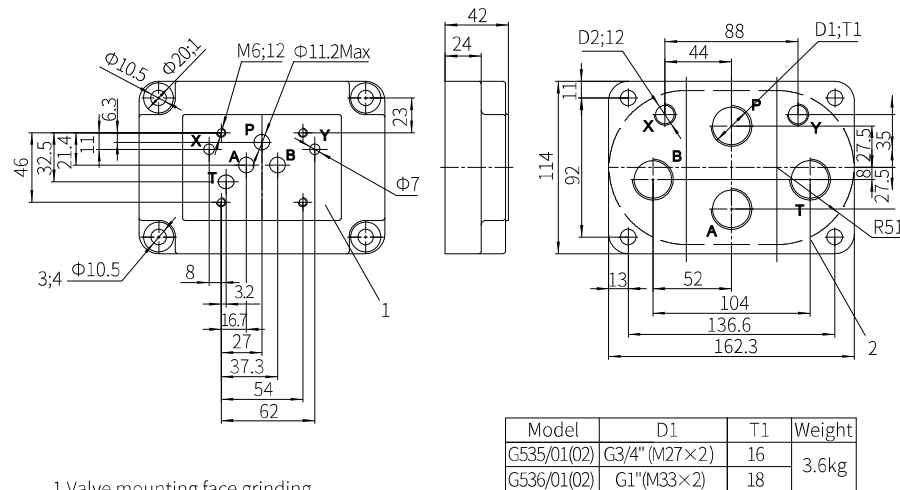

- 1 Valve mounting face grinding
- 2 Front panel opening
- 3 Valve fixing screw holes
- 4 Valve fixing screw: 4pcs hexagon screws M6, GB/T70.1-10.9 grade



- 1 Locating pin hole
- 2 Valve fixing screw holes
- 3 Valve mounting face grinding
- 4 Front panel opening
- 5 Valve fixing screw:
4pcs M10, GB/T70.1-10.9 grade
4pcs M6, GB/T70.1-10.9 grade