

01

Modular Hydraulic Control Check Valve

Model: Z2S10...3XJ



- ◆ Size 10
- ◆ Maximum working pressure 315 bar
- ◆ Maximum working flow 120 L/min

Contents

Function description, sectional drawing	02
Models and specifications	02
Functional symbols	03
Technical parameters	03
Characteristic curve	04
Component size	04

Features

- For vertical stacking installation
- One or two working oil ports blocked for leakage-free as required

Any part of this brochure can not be reproduced, edited, copied and disseminated electronically in any way without authorization of Jiayite Hydraulics company. As the product is in constant development and innovation, the information in this brochure is not specific to the special conditions or applicability of a specific industry, thus Jiayite Hydraulics company is not responsible for any incomplete or inaccurate description generated.



Function description, sectional drawing

The Z2S type is a superimposed structure hydraulically controlled check valve. This type of valve can keep one or two working oil ports leakage-free even if it is shut down for a long time.

There is a free flow in the direction A1 to A2 or B1 to B2 but closed in the opposite direction. When the oil flows from A1 to A2, the spool (1) is pushed to the right under pressure, opens the ball valve core (2) and then opens the sleeve valve core (3).

In order to ensure that the valve is closed correctly in the center position, the working oil port of the directional valve must be connected to the tank when it is in the neutral position (see circuit example).

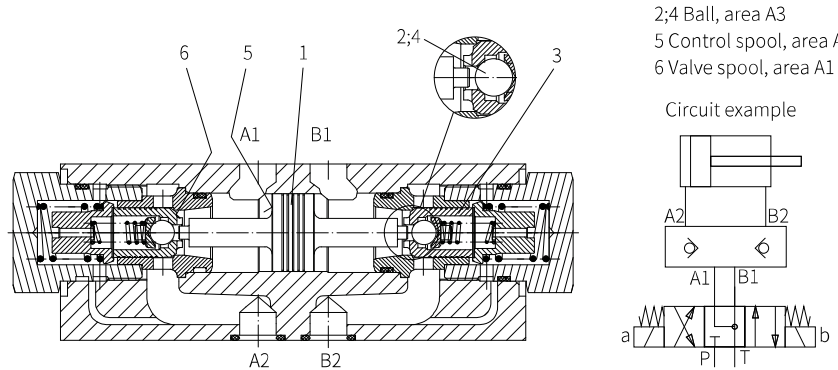

Model Z2S10...-3XJ/

Models and specifications

Z2S	10			3X	J	*
modular hydraulic control check valve	=10					more information in text
size 10						sealing material
leakage-free blocking in oil port A and B	= -					No code= NBR seals
oil port A	= A					V= FKM seals (consult for other seals)
oil port B	= B					J= Rekith
cracking pressure						3X= 30 to 39 series (30 to 39 series installation and connection size unchanged)
1.5 bar	= 1					
3 bar	= 2					
6 bar	= 3					
10 bar	= 4					

Functional symbols

(①= Valve side, ②= Subplate side)

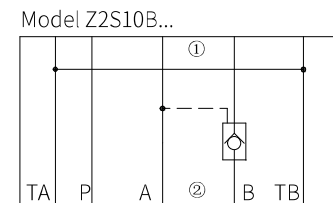
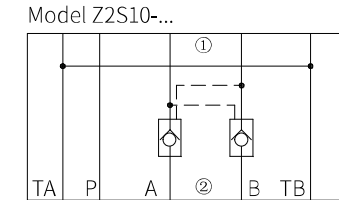
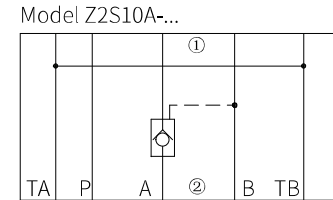

Technical Parameters

Overview		
Weight	kg	about 3
Installation position		Optional
Environment temperature range	°C	-30 to + 50 (NBR seal) -20 to + 50 (FKM seal)
Hydraulic		
Maximum working pressure	bar	315
Cracking pressure in free flow direction		See characteristic
Maximum flow	L/min	120
Flow direction		See the symbol
Oil fluid		Mineral oil (HL, HLP) ¹⁾ in accordance with DIN 51524; Fast living organisms degraded oil according to VDMA 24568; HETG (Rapeseed oil) ¹⁾ ; HEPG (Polyethyleneglycol) ²⁾ ; HEES (Synthetic Fats) ²⁾
Oil temperature range	°C	-30 to + 80 (NBR seal) -20 to + 80 (FKM seal)
Viscosity range	mm ² /s	2.8 to 500
Cleanliness of oil		The maximum allowable pollution level of oil is ISO4406 Class 20 / 18 / 15
Area ratio		A1/A2=1/3; A3/A2=1/11.5 (See section view above)

1) For NBR seal and FKM seal.

2) Only for FKM seal.

3) The oil must meet the cleanliness degree requested by the components in the hydraulic system. Effective oil filtration can prevent failure and increase the service life of the components.

Characteristic curve

(Measured when using HLP46, $t_{oil} = 40^\circ\text{C} \pm 5^\circ\text{C}$)

$\Delta p - q_v$ Characteristic curve

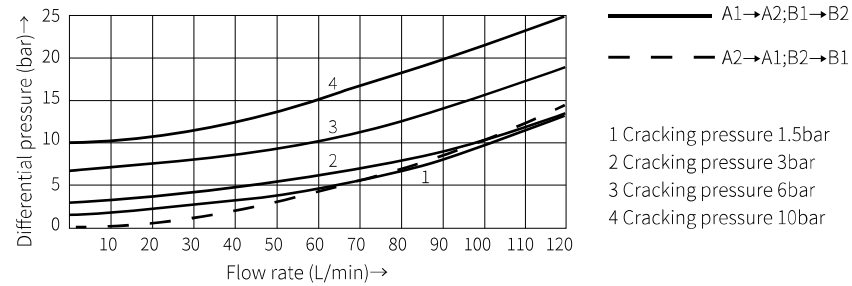

01

Component size

Size unit: mm

Model Z2S10...-3XJ/...

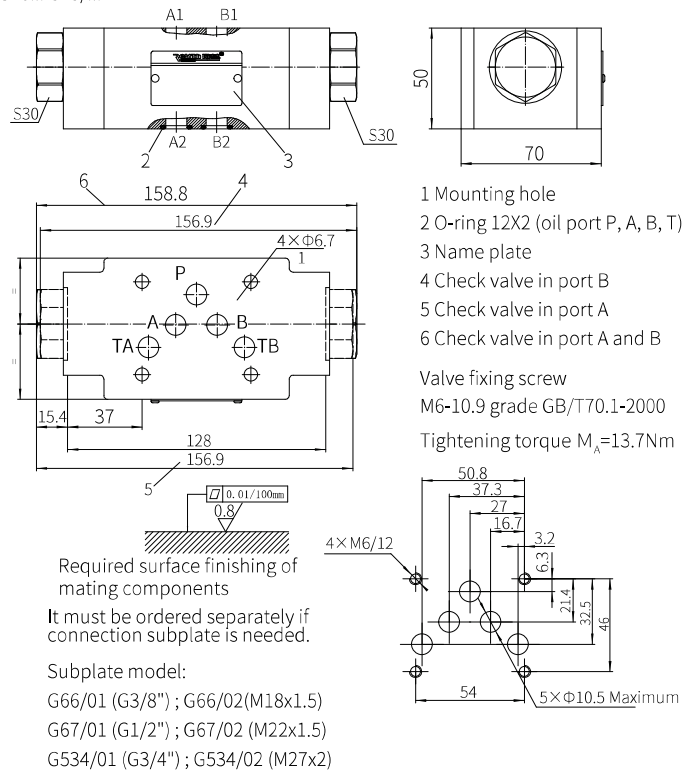

Modular Hydraulic Control Check Valve

Model: Z2S16...5XJ



- ◆ Size 16
- ◆ Maximum working pressure 315 bar
- ◆ Maximum working flow 300L/min

Contents

Function description, sectional drawing	02
Models and specifications	02
Functional symbols	03
Technical parameters	03
Characteristic curve	04
Component size	04

Features

- One or two working ports blocked without leakage
- For vertical installation
- 4 cracking pressures, optional